



## Packaging Information

PACKAGING ORDERING CODE		
ANTI-STATIC PACKAGE CODE	PREFERRED PACKAGE CODE	PACKAGING DESCRIPTION
51	P	Bulk
52, 52T	P	DO-214/215AA (SMB), 12 mm tape, 7" diameter plastic reel
2A		Horizontal ammo pack (metric) or specified box height
2C		DO-214/215AA (SMB), 12 mm tape, 7" diameter paper reel
2D	P	DO-218AB (SM5-8A), 24 mm tape, 13" diameter plastic reel, anode towards sprocket hole
2E	P	DO-218AB (SM5-8A), 24 mm tape, 13" diameter plastic reel, cathode towards sprocket hole
2G		DO-214AC (SMA), 12 mm tape, 7" diameter paper reel
2KA		DO-214BA (GF1), 12 mm tape, 7" diameter paper reel
2M		Tube packaging for 5KP/6KA type lead formed components
53		26 mm horizontal taping and ammo box packaging
54	P	52.4 mm horizontal tape, 13" diameter paper reel class I
4E		Euroform, reel cathode first off reel non lead coated
4F		Euroform, ammo pack, cathode first out of box non lead coated
4G		Euroform, reel cathode last off reel non lead coated
4H		Euroform, ammo pack, cathode last out of box non lead coated
55		DO-214/215AA (SMB), 12 mm tape, 13" diameter paper reel
5A, 5AT	P	DO-214AC (SMA), 12 mm tape, 13" diameter plastic reel
5B, 5BT	P	DO-214/215AA (SMB), 12 mm tape, 13" diameter plastic reel
5CA	P	DO-214BA (GF1), 12 mm tape, 13" diameter plastic reel
56		Avisert, cathode up, cathode first off reel
57T	P	DO-214/215AB (SMC), 16 mm tape, 7" diameter plastic reel
58		Avisert, cathode up, cathode first out of ammo pack
59		DO-214/215AB (SMC), 16 mm tape, 13" diameter paper reel
9AT	P	DO-214/215AB (SMC), 16 mm tape, 13" diameter plastic reel
9C		DO-214/215AB (SMC), 16 mm tape, 7" diameter paper reel
60		Avisert, cathode down, anode first off reel
61, 61T	P	DO-214AC (SMA), 12 mm tape, 7" diameter plastic reel
62		Avisert, cathode down, anode first out of ammo pack
63		DO-214AC (SMA), 12 mm tape, 13" diameter paper reel
64		Panasert, cathode up, cathode first off reel
65		Panasert, cathode up, anode first out of ammo pack
66		Panasert, cathode up, cathode first out of ammo pack
67A	P	DO-214BA (GF1), 12 mm tape, 7" diameter plastic reel
68		Panasert, cathode down, anode first off reel
69A		DO-214BA (GF1), 12 mm tape, 13" diameter paper reel
70		Panasert, cathode down, anode first out of ammo pack
71		Panasert, cathode up, cathode first off reel, lead coat
72		Bulk pack for KBPM, GBL, GBU and special axial-leaded formed devices
73	P	52.4 mm horizontal tape and ammo box packaging, class I
74		Panasert, cathode up, cathode first out of ammo pack, lead coat
75		DO-213AB (GL41), 12 mm tape, 7" diameter paper reel
76		DO-213AB (GL41), 12 mm tape, 13" diameter paper reel
77	P	DFS bridge, 16 mm tape, 13" diameter paper reel
79		Panasert, cathode down, cathode first off reel
80	P	TO-269AA (MB-S) bridge, 12 mm tape, 13" diameter paper reel
81	P	TO-263AB 24 mm tape, 13" diameter reinforced hub plastic reel
8W	P	For wire bond TO-263AB 24 mm tape, 13" diameter reinforced hub plastic reel

# Packaging Information

Vishay General Semiconductor



PACKAGING ORDERING CODE		
ANTI-STATIC PACKAGE CODE	PREFERRED PACKAGE CODE	PACKAGING DESCRIPTION
82		DO-213AA (GL34), 8 mm tape, 7" diameter paper reel
83	P	<b>DO-213AA (GL34) 8 mm tape, 13" diameter plastic reel</b>
84A	P	<b>DO-220AA (SMP) 12 mm tape, 7" diameter plastic reel</b>
85A	P	<b>DO-220AA (SMP) 12 mm tape, 13" diameter plastic reel</b>
86A	P	<b>SMPC, 12 mm tape, 7" diameter plastic reel</b>
87A	P	<b>SMPC, 12 mm tape, 13" diameter plastic reel</b>
38		Lead forming buck packaging in anti-static bags
89A	P	<b>MicroSMP, 8 mm tape, 7" diameter plastic reel</b>
90		Euroform, reel, cathode first off reel, lead coated
91		Euroform, ammo pack, cathode first out of ammo pack, lead coated
92		Euroform, reel, cathode last off reel, lead coated
93		Euroform, ammo pack, cathode last out of ammo pack, lead coated
45	P	<b>Anti-static tube packaging for TO-220, TO-247AD, DFM, DFS, MBS, KBPM, GBL and GBU</b>
4W	P	<b>Anti-static tube packaging for wire bond TO-220, ITO-220, TO-262 and TO-263</b>
96	P	<b>DO-213AB (GL41), 12 mm tape, 7" diameter plastic reel</b>
97	P	<b>DO-213AB (GL41), 12 mm tape, 13" diameter plastic reel</b>
98	P	<b>DO-213AA (GL34), 8 mm tape, 7" diameter plastic reel</b>
100		MPG06 pseudo radial tape, cathode first out of ammo pack
TR	P	<b>SMA, 12 mm tape, 7" diameter plastic reel <sup>(1)</sup></b>
TR3	P	<b>SMA, 12 mm tape, 13" diameter plastic reel <sup>(1)</sup></b>

## Notes

<sup>(1)</sup> Formerly sold by Vishay Telefunken® (Telefunken® is a registered trademark of Electro Holding GmbH).

- "P" and bold letter denotes preferred package code.
- A "T" suffix added to the packaging codes for SMA, SMB and SMC products indicates that the patented folded-frame construction is used. This does not apply to TR and TR3 codes or TRANSZORB® TVS in SMA and SMB.

BULK PACKAGING						
CASE TYPES	PREFERRED PACKAGE CODE	PACKAGING	BOX SIZE		QUANTITY	
			INCHES	cm	EA.	
DF-M, DF-S, DFL-S	45	Anti-static plastic tubes	17.4 length	44.1 length	50	
GSIB-3G	45	Anti-static plastic tubes	25.1 length	63.9 length	20	
GSIB-5S	45	Anti-static plastic tubes	24.2 length	61.5 length	20	
GBU	45	Anti-static plastic tubes	18.5 length	47 length	20	
GBL	45	Anti-static plastic tubes	17.5 length	44.5 length	20	
KBPM	45	Anti-static plastic tubes	18.5 length	47 length	30	
TO-220AB/AC, ITO-220AC/AB, TO-262AA	45, 4W	Anti-static plastic tubes	21.0 length	53.7 length	50	
TO-247AD	45	Anti-static plastic tubes	20.0 length	50.8 length	30	
TO-269AA (MB-S)	45	Anti-static plastic tubes	20.3 x 0.41	51.5 x 1.04	100	
KBPM	51	Anti-static PVC tray	12.5 x 6.5 x 1.25	31.7 x 16.5 x 3.17	600	
GBL	51	Anti-static PVC tray	12.5 x 6.1 x 1.0	30.9 x 15.5 x 2.5	400	
GBPC12-35W	51	Paper box	12.5 x 12.5 x 1.7	31.7 x 31.7 x 4.3	100	
GBPC1, GBPC6	51	Paper box	7.5 x 7.5 x 1.43	19.0 x 19.0 x 3.6	100	
KBL	51	Anti-static PVC tray	12.2 x 6.1 x 1.5	30.9 x 15.5 x 3.8	300	
GBPC12-35	51	Paper box	12.5 x 12.5 x 1.7	31.7 x 31.7 x 4.3	100	
KBU4, 6, 8	51	Anti-static PVC tray	12.2 x 6.1 x 1.5	30.9 x 15.5 x 3.8	250	
WOG, 2WOG	51	Plastic bags	-	-	100	
GBU, /BU	51	Paper tray	13.1 x 6.6 x 1.2	33.2 x 17.2 x 3.0	250	
KBPM	72	Paper box	7.4 x 7.4 x 1.5	18.8 x 18.8 x 3.8	200	

## AXIAL-LEADED TAPE AND REEL PACKAGING

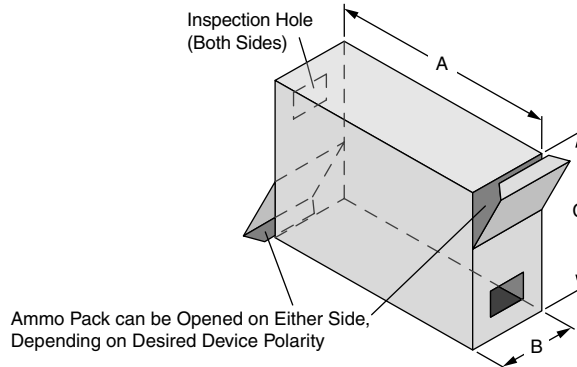

All axial-leaded devices are packed in accordance with EIA standard RS-296-E. The diagrams given below refer to these specifications.

TABLE 1 - AMMO PACK PACKAGING						
PACKAGING	AVAILABLE PRODUCT OUTLINES	PREFERRED PACKAGE CODE	DIMENSION A	DIMENSION B	DIMENSION C	QUANTITY BOX
26 mm horizontal tape, ammo pack	DO-204AL (DO-41), MPG06	53	9.7" (247 mm)	1.7" (44 mm)	3.7" (95 mm)	3.0K
	DO-204AC	53				1.5K
	P300	53				0.75K
52 mm horizontal tape, ammo pack	DO-204AL, MPG06	73	10.0" (255 mm)	3.15" (80 mm)	4.53" (115 mm)	3.0K
	DO-204AC	73				2.0K
	DO201AD, GP20	73				1.0K
	P600	73				0.3K
Radial (avisert, panasert, euroform) vertical tape	GP10-E, RGP10-E, GP10-E, RGP10-E	58, 62, 65, 66, 70	13.4" (340 mm)	1.8" (47 mm)	7.9" (200 mm)	2.0K
		91, 93				2.5K
		70, 74				2.0K
Pseudo/radial tape, ammo pack	MPG06	100	13.4" (340 mm)	1.8" (47 mm)	7.9" (200 mm)	2.5K

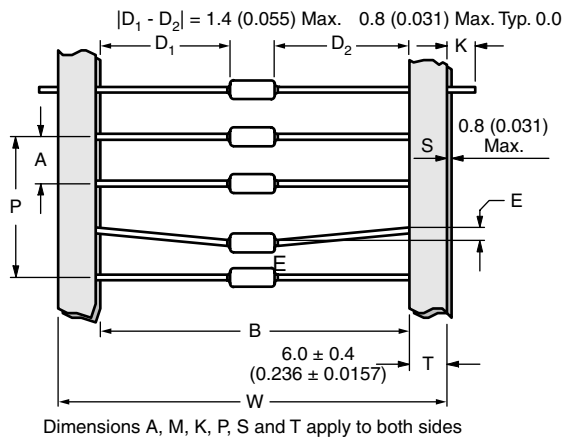

Dimensions in millimeters (inches)

Description	Symbol	
Component Pitch	A	2, 3
Inside Tape Spacing	B	2, 3
Lead to Lead Eccentricity	D1 - D2	-
Lead Extension	K	-
Lead Bending	E	2
Cumulative Pitch	P	3
Exposed Adhesive	S	-
Tape Width	T	-

All polarized components shall be oriented in the same direction

Fig. 1

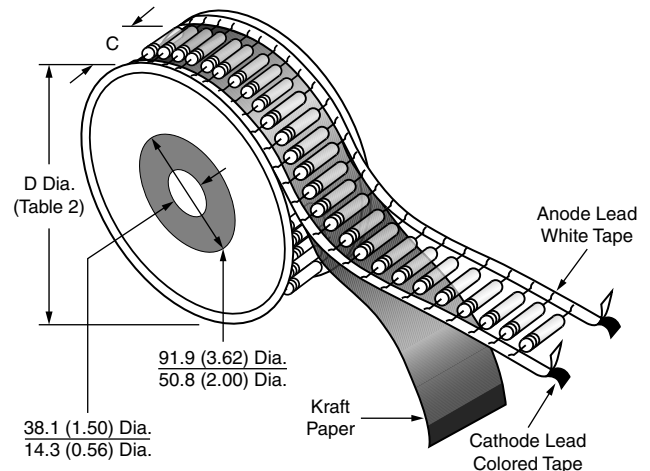

The "C" dimension of Fig. 2 is between flanges of the component reel and shall be 1.5 mm (0.059") to 8.00 mm (0.315") greater than the overall taped component width "W" (Fig. 1). Where "W" dimension is 68.2 mm (2.68") max.

Fig. 2

## AXIAL-LEADED TAPE AND REEL PACKAGING

**TABLE 2 - REEL AND AMMO PACK TAPING SPECIFICATIONS**

COMPONENT CASE TYPE	PREFERRED PACKAGE CODE	UNITS PER REEL	COMPONENT PITCH "A" Fig. 1		INSIDE TAPE SPACING "B" Fig. 1		REEL DIMENSION "D" Fig. 2		LEAD BENDING "E" Fig. 1	
			EA.	INCHES	mm	INCHES	mm	INCHES	mm	INCHES
1.5KA (PAR)	54	1400	0.395	10.0	2.06	52.4	13.0	330	0.047	1.2
DO-204AC	54	4000	0.200	5.0	2.06	52.4	13.0	330	0.047	1.2
DO-201AD	54	1400	0.395	10.0	2.06	52.4	13.0	330	0.047	1.2
DO-204AL	54	5500	0.200	5.0	2.06	52.4	13.0	330	0.047	1.2
DFS Surface Mount	77	1500	0.472	12.0	-	-	13.0	330	Fig. 13	1.95
DO-214BA (GF1)	67A/5CA	1500/6500	0.157	4.0	-	-	7.0/13.0	178/330	Fig. 13	0.31/2.07
DO-213AA (GL34)	98/83	2500/9000	0.157	4.0	-	-	7.0/13.0	178/330	Fig. 13	0.471/1.41
DO-213AB (GL41)	96/97	1500/5000	0.157	4.0	-	-	7.0/13.0	178/330	Fig. 13	0.62/1.96
GP10E Radial	Fig. 7 and Fig. 8	2500	0.500	12.7	-	-	13.0	330	0.079	2.0
GP10E	54	5500	0.200	5.0	2.06	52.4	13.0	330	0.047	1.2
GP20/1.5KE	54	1400	0.395	10.0	2.06	52.4	13.0	330	0.047	1.2
MPG06	54	5500	0.200	5.0	2.06	52.4	13.0	330	0.047	1.2
MPG06 Radial	50J	2000	0.500	12.7	-	-	-	-	0.080	2.0
P600	54	800	0.395	10.0	2.06	52.4	13.0	330	0.047	1.2
SMP	84A/85A	3000/ 10 000	0.157	4.0	-	-	7.0/13.0	178/330	Fig. 13	
MicroSMP	89A	4500	0.157	4.0	-	-	7.0	178	Fig. 13	
SMPC	86A/87A	1500/6500	0.314	8.0	-	-	7.0/13.0	178/330	Fig. 13	
DO-214AC (SMA)	61, 61T, TR/5A, 5AT, TR3	1800/7500	0.157	4.0	-	-	7.0/13.0	178/330	Fig. 13	
DO-214AA (SMB)	52, 52T/5B, 5BT	750/3200	0.314	8.0	-	-	7.0/13.0	178/330	Fig. 13	
DO-214AB (SMC)	57T/9AT	850/3500	0.472	12.0	-	-	7.0/13.0	178/330	Fig. 13	
DO-218AB	2D	750	0.630	16.0	-	-	13.0	330	Fig. 13	
TO-263AB	81, 8W	800	0.630	16.0	-	-	13.0	330	Fig. 13	
TO-269AA (MB-S)	80	3000	0.315	8.0	-	-	13.0	330	Fig. 13	

**Note**

- Package codes, 61/5A, 52/5B are matrix-frame constructions for TRANSZORB® TVS in SMA and SMB only.

**TABLE 3 - COMPONENT AND INSIDE HORIZONTAL TAPE SPACING**

COMPONENT BODY DIAMETER	COMPONENTS SPACING A (LEAD TO LEAD)	INSIDE TAPE SPACING "B"	CUMULATIVE PITCH TOLERANCE
0 mm to 5 mm (0.0" to 0.197")	5.0 mm ± 0.5 mm (0.197" ± 0.020")	26 mm + 1.5 mm/- 0.0 mm (1.024" + 0.059"/- 0.0")	Not to exceed 1.5 mm (0.059") over 6 consecutive components
0 mm to 5 mm (0.0" to 0.197")	5.0 mm ± 0.5 mm (0.197" ± 0.020")	52.4 mm + 1.5 mm/- 0.4 mm (2.062" + 0.059"/- 0.016")	
5.01 mm to 10 mm (0.197" to 0.394")	10 mm ± 0.5 mm (0.394" ± 0.020")	52.4 mm + 1.5 mm/- 0.4 mm (2.062" + 0.059"/- 0.016")	

### DIMENSIONS in millimeters (inches)

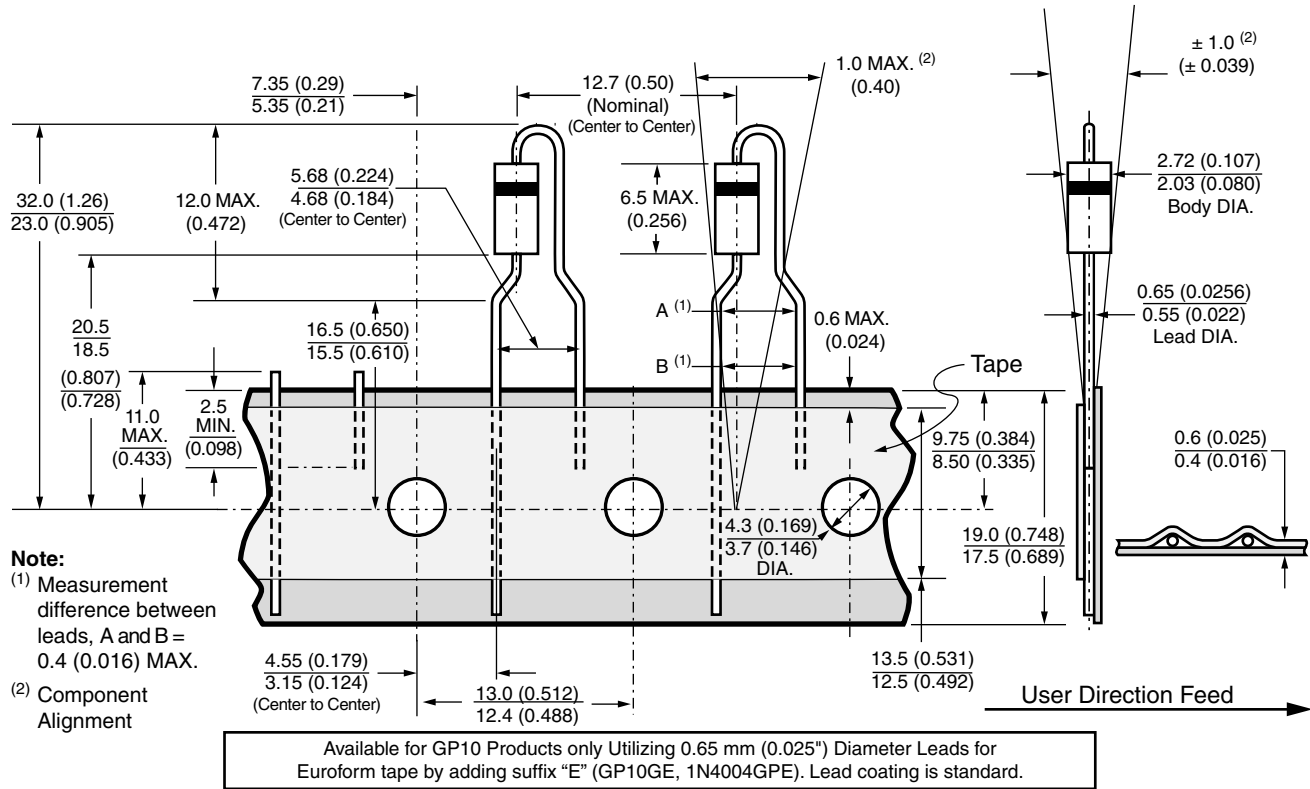

Fig. 3 - Euroform

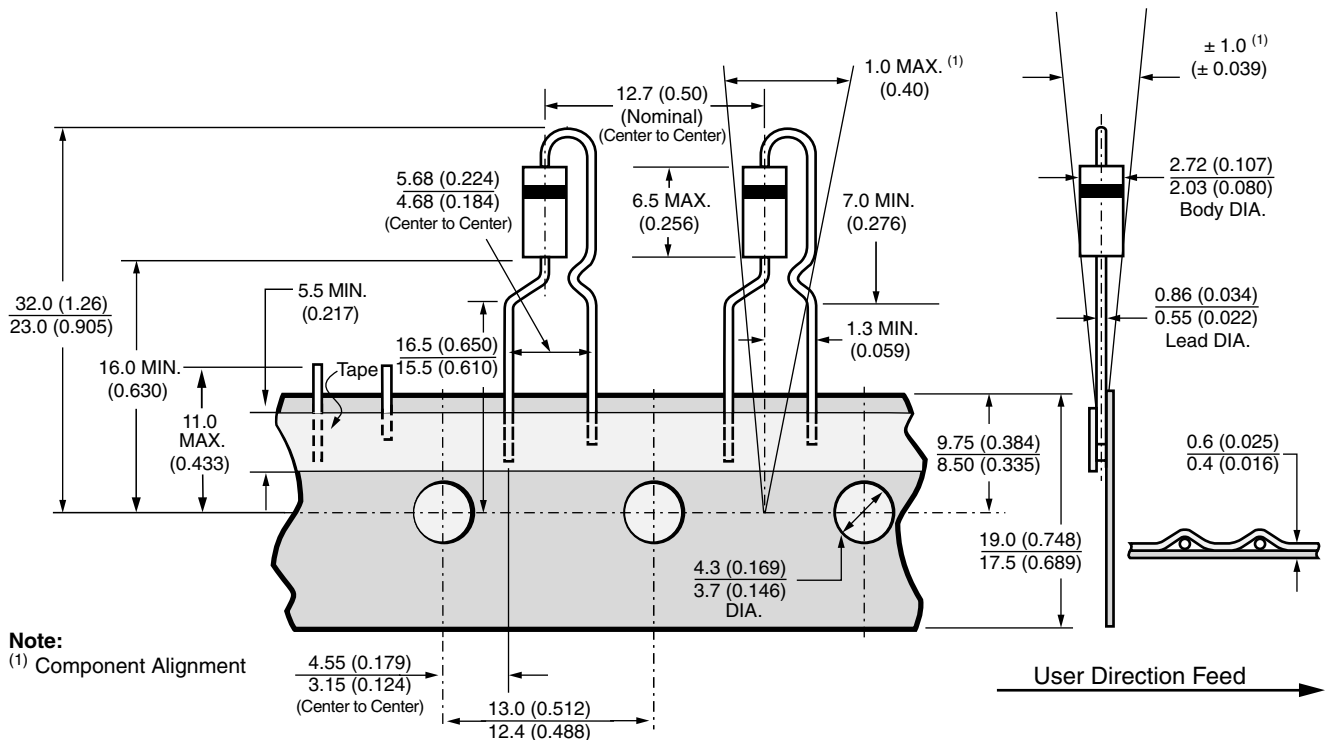
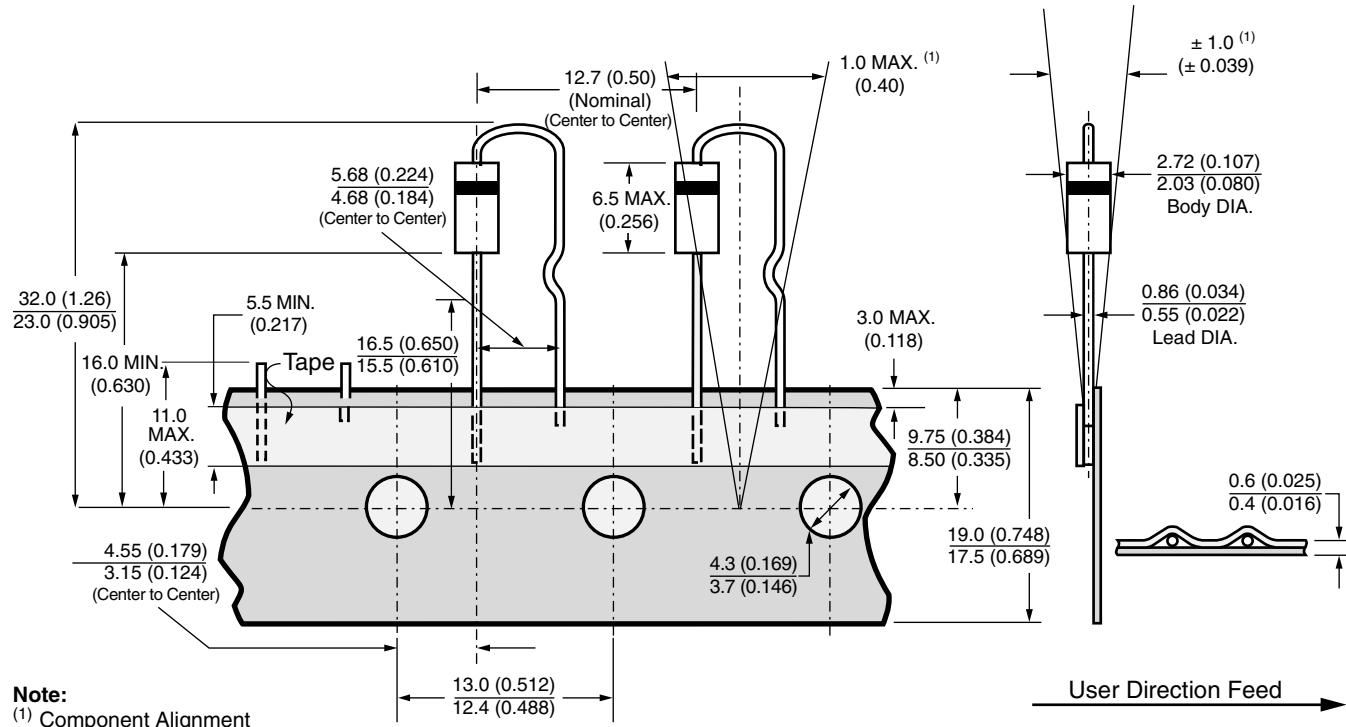

Fig. 4 - Panasert

### DIMENSIONS in millimeters (inches)



**Note:**  
(1) Component Alignment

Available only for GP10 style products utilizing 0.65 mm (0.025") or 0.76 mm (0.030") diameter leads for Panasert and Avisert tape. Lead coating is available on GP10 products only.

Standard Polarity Cathode Oriented Away from Sprocket Holes (Optional Polarity Cathode Oriented Toward Sprocket Holes)

Fig. 5 - Avisert

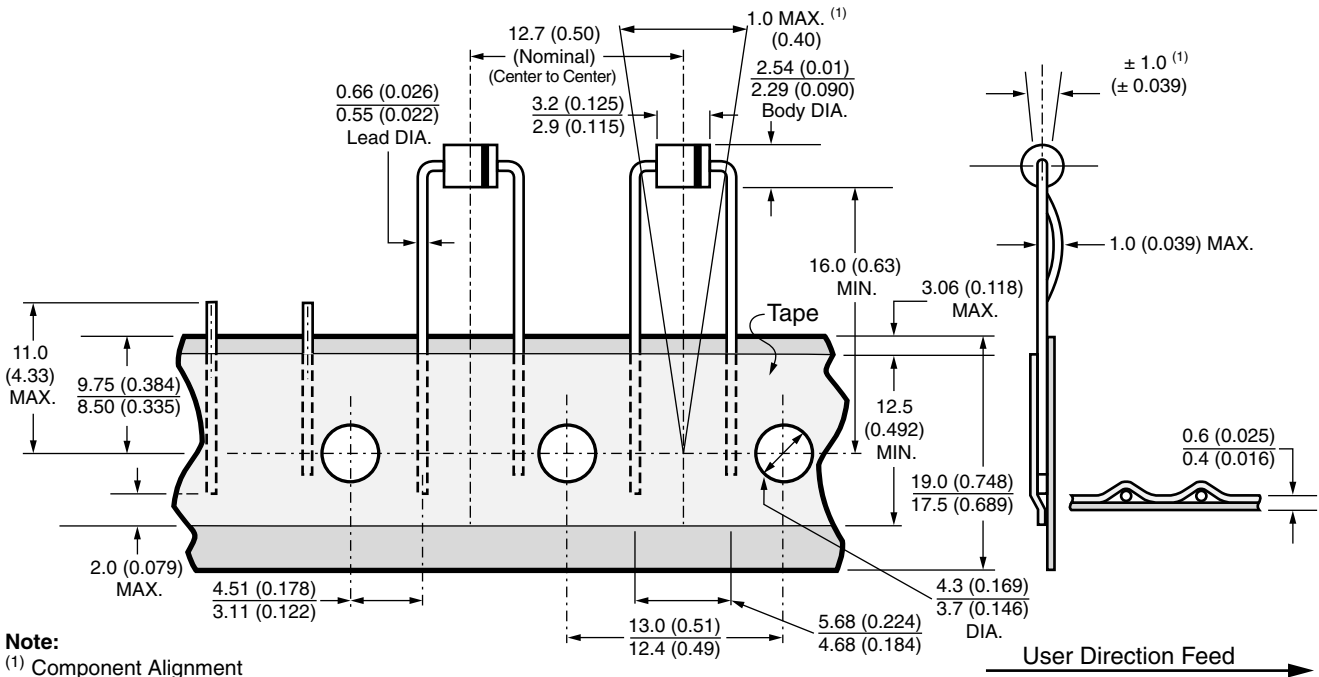

**Note:**  
(1) Component Alignment

Available only for MPG06 Product in Ammo Pack in Accordance with EIA Standard RS-468-A Utilizing 0.61 mm (0.024") Diameter Leads. Maximum Cumulative Pitch Tolerance: 1.0 mm (0.039")/20 Pitch.

Fig. 6 - Pseudo Radial

## RADIAL TAPE PACKAGING

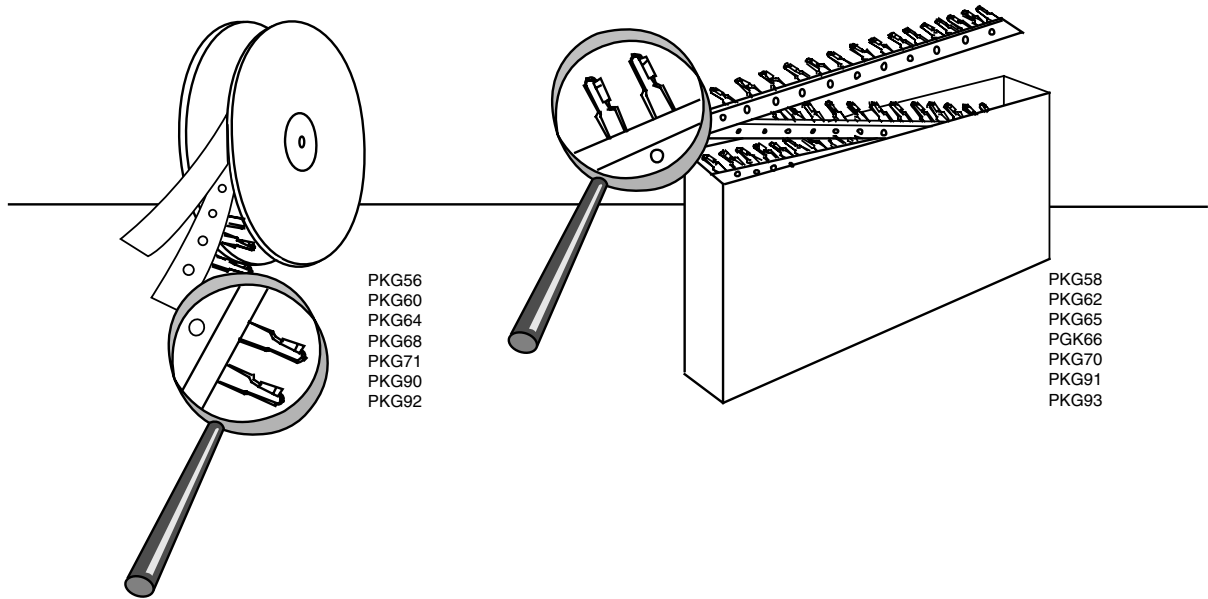

PKG56  
PKG60  
PKG64  
PKG68  
PKG71  
PKG90  
PKG92

PKG58  
PKG62  
PKG65  
PKG66  
PKG70  
PKG91  
PKG93

Fig. 7 and Fig. 8 - Reel and Ammo Box Packaging

PREFERRED PACKAGE CODE		
AVISERT	PANASERT	EUROFORM
PKG56	PKG64	PKG90
PKG58	PKG65	PKG91
PKG60	PKG66	PKG92
PKG62	PKG68	PKG93
	PKG70	
	PKG71	
	PKG74	
	PKG79	

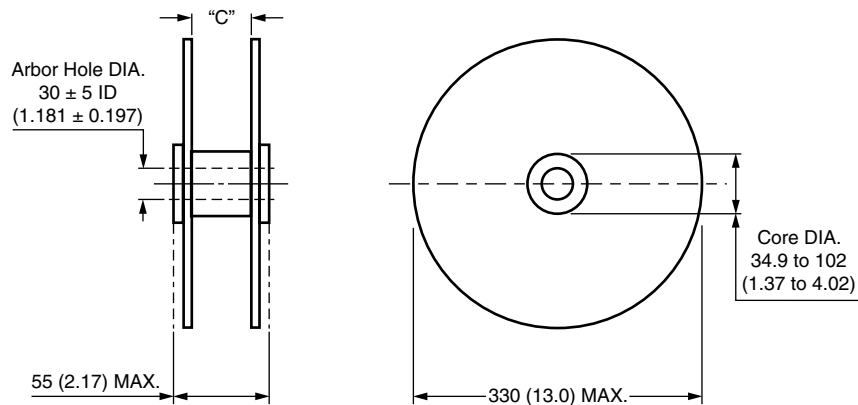

Fig. 9 - Reel Dimensions

### Notes

- "C" dimension between the reel flanges shall be governed by the overall width of the taped components and shall be 1.5 mm (0.057") to 8.0 mm (0.315") greater than the overall width
- All leaded devices are packaged in accordance with EIA standard RS-468-A specification and are available on reel or in fan fold box (ammo pack)
- All dimensions are in millimeters and (inches). The above packaging is only available from Taiwan.



## SURFACE MOUNT TAPE AND REEL PACKAGING

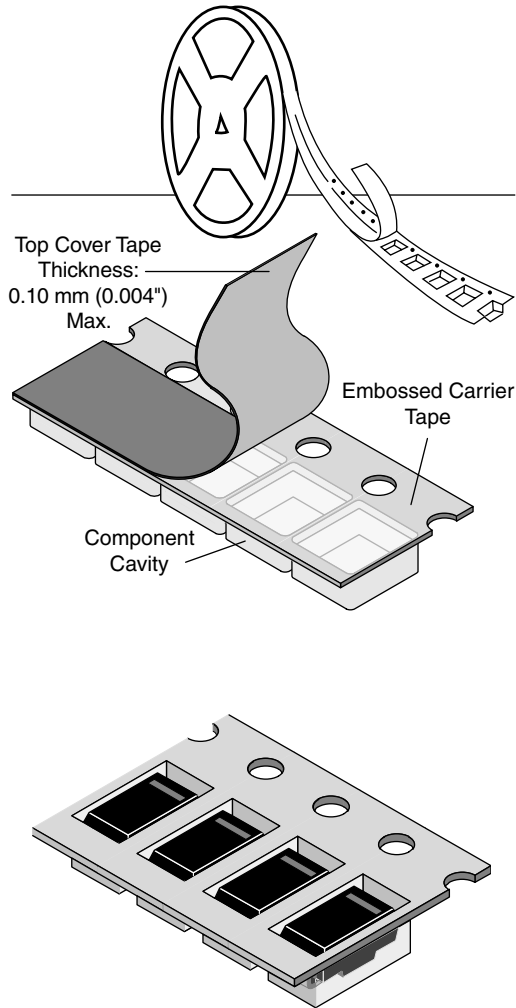

Fig. 10

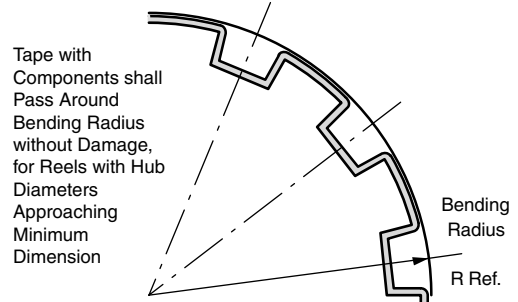

Fig. 11

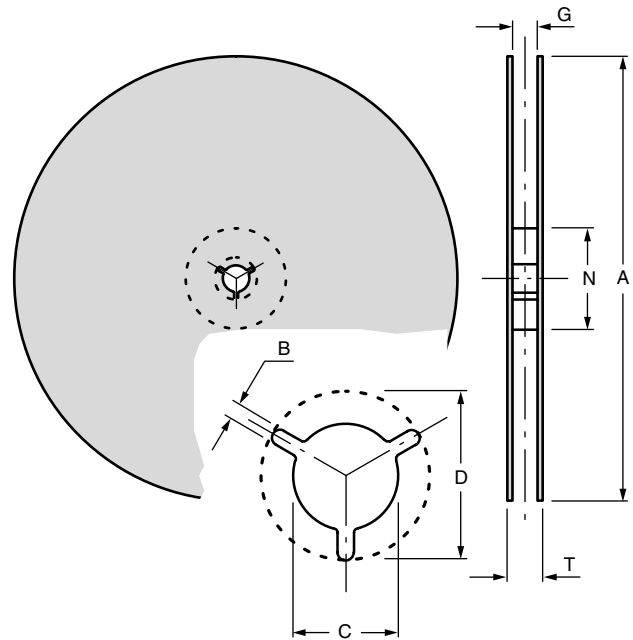
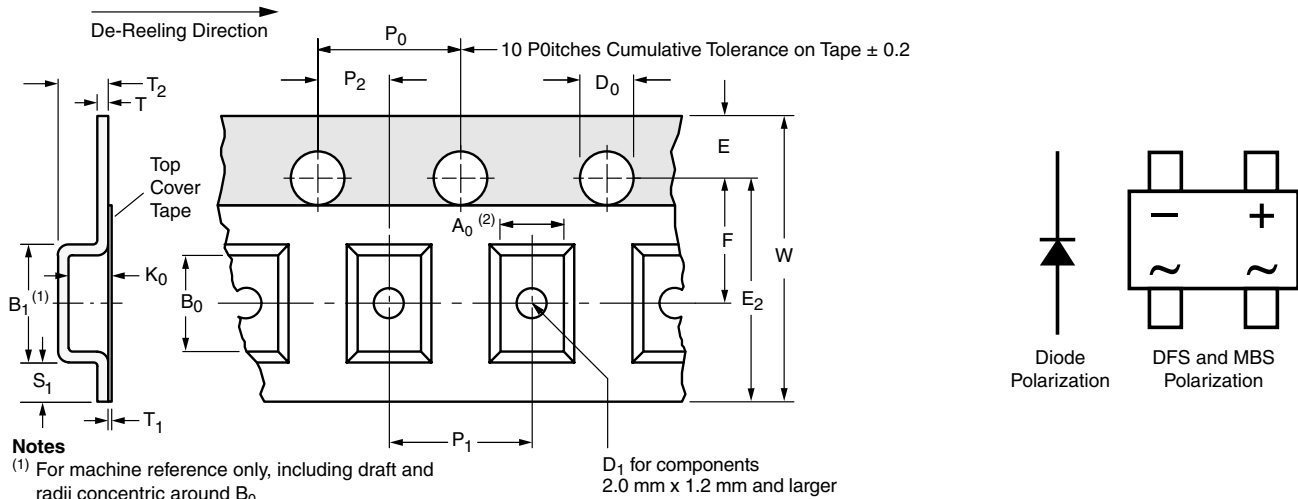

Fig. 12

<b>DIMENSIONS</b> in millimeters (inches)							
TAPE SIZE	A MAX.	B MAX.	C	D MAX.	N MIN.	G MAX.	T MAX.
8 mm (0.315)	330 ± 2.0 (13.0 ± 0.079) 178 ± 2.0 (7.0 ± 0.079)	2.5 (0.098)	13.0 ± 0.5 (0.51 ± 0.020)	21.8 (0.858)	79.0 (3.11) for 13" 61.0 (2.40) for 7"	9.9 (0.389)	14.4 (0.567)
12 mm (0.472)	330 ± 2.0 (13.0 ± 0.079) 178 ± 2.0 (7.0 ± 0.079)	2.5 (0.098)	13.0 ± 0.5 (0.51 ± 0.020)	21.8 (0.858)	79.0 (3.11) for 13" 61.0 (2.40) for 7"	14.4 (0.567)	19.4 (0.764)
16 mm (0.630)	330 ± 2.0 (13.0 ± 0.079) 178 ± 2.0 (7.0 ± 0.079)	2.5 (0.098)	13.0 ± 0.5 (0.51 ± 0.020)	21.8 (0.858)	79.0 (3.11) for 13" 61.0 (2.40) for 7"	18.4 (0.724)	23.4 (0.921)
24 mm (0.945)	330 ± 2.0 (13.0 ± 0.079)	2.5 (0.098)	13.0 ± 0.5 (0.51 ± 0.020)	21.8 (0.858)	79.0 (3.11)	26.4 (1.039)	31.2 (1.228)



## SURFACE MOUNT TAPE AND REEL PACKAGING



### Notes

(1) For machine reference only, including draft and radii concentric around  $B_0$

$D_1$  for components 2.0 mm x 1.2 mm and larger

(2) See note 1 and table

Fig. 13

8 mm, 12 mm, 16 mm, AND 24 mm EMBOSSED TAPE in millimeters (inches)								
TAPE SIZE	$D_0$	$E_1$	$P_0$	$P_2$	$A_0, B_0, K_0$	$S_1$ MIN.	$T$ MAX.	$T_1$ MAX.
8 mm, 12 mm	$1.5 \pm 0.1/-0$ ( $0.059 \pm 0.004$ )	$1.75 \pm 0.1$ ( $0.069 \pm 0.004$ )	$4.0 \pm 0.1$ ( $0.157 \pm 0.004$ )	$2.0 \pm 0.05$ ( $0.79 \pm 0.002$ )	(1)	0.6 (0.024)	0.600 (0.024)	0.1 (0.004)
16 mm, 24 mm				$2.0 \pm 0.1$ ( $0.79 \pm 0.004$ )				

DIMENSIONS in millimeters (inches)									
CASE TYPE	TAPE SIZE	$B_1$ MAX.	$D_1$ MIN.	$E_2$ MIN.	F	$P_1$	R REF.	$T_2$ MAX.	W
DO-213AA (GL34)	8 mm (0.315)	4.2 (0.165)	1.0 (0.39)	6.25 (0.246)	$3.5 \pm 0.05$ ( $0.138 \pm 0.002$ )	$4.0 \pm 0.10$ ( $0.57 \pm 0.004$ )	25 (0.984)	2.4 (0.094)	$8.0 \pm 0.30$ ( $0.315 \pm 0.012$ )
MicroSMP		3.28 (0.129)		6.05 (0.238)				1.919 (0.076)	
DO-213AB (GL41)	12 mm	8.2 (0.323)	1.5 (0.059)	10.25 (0.404)	$5.5 \pm 0.05$ ( $0.217 \pm 0.002$ )	$4.0 \pm 0.10$ ( $0.57 \pm 0.004$ )	30 (1.181)	4.5 (0.177)	$12.0 \pm 0.30$ ( $0.472 \pm 0.012$ )
DO-214BA (GF1)								$3.15 \pm 0.10$ ( $1.00 \pm 0.004$ )	
DO-214AC(SMA)								$2.54 \pm 0.10$ ( $1.24 \pm 0.004$ )	
SMP								$1.74 \pm 0.10$ ( $0.069 \pm 0.004$ )	
SMPC								$1.33 \pm 0.10$ ( $0.052 \pm 0.004$ )	
DO214/215 (SMB) TO-269AA (MB-S)	16 mm (0.630)	8.2 (0.323)	1.5 (0.059)	14.25 (0.561)	$7.5 \pm 0.05$ ( $0.295 \pm 0.002$ )	$8.0 \pm 0.10$ ( $0.315 \pm 0.004$ )	30 (1.181)	$2.67 \pm 0.10$ ( $1.05 \pm 0.004$ )	$16.0 \pm 0.2$ ( $0.630 \pm 0.008$ )
DO-214/215AB (SMC)								$2.5 \pm 0.10$ ( $0.100 \pm 0.004$ )	
DFS								$3.81 \pm 0.10$ ( $0.150 \pm 0.004$ )	
TO-263AB DO-218AB	24 mm (0.945)	20.1 (0.791)	1.5 (0.059)	22.25 (0.876)	$11.5 \pm 0.1$ ( $0.453 \pm 0.004$ )	$16.0 \pm 0.10$ ( $0.630 \pm 0.004$ )	30 (1.181)	$5.21 \pm 0.10$ ( $0.205 \pm 0.004$ )	$24.0 \pm 0.3$ ( $0.945 \pm 0.008$ )

### Notes

(1)  $A_0$ ,  $B_0$ , and  $K_0$  are determined by the maximum dimensions of the component size. The clearance between the component and the cavity must be within 0.05 mm (0.002") min. to 0.5 mm (0.02") max. for 8 mm tape and 12 mm tape, 0.15 mm (0.066") min. to 0.90 mm (0.035") max. for 16 mm tape and 0.15 mm (0.006") min. to 1.0 mm (0.039") max. for 24 mm tape.

(2) All surface mount components are packed in accordance with EIA standard 481-C